



**RAE**

**YC476 - Power Thyristor**

**500 - 1400 V<sub>DRM</sub>; 600A rms**

\*\*\*\*\*

**HIGH POWER THYRISTOR FOR INVERTER CONTROL APPLICATIONS**

**Features:**

- . All Diffused Structure
- . Interdigitated Amplifying Gate Configuration
- . Blocking capability up to 1400 volts
- . Guaranteed Maximum Turn-Off Time
- . High dV/dt Capability
- . Pressure Assembled Device

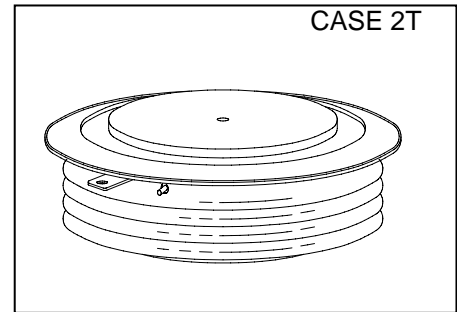

**ELECTRICAL CHARACTERISTICS AND RATINGS**

**Blocking - Off State**

Device Type	V <sub>R</sub> RM (1)	V <sub>D</sub> RM (1)	V <sub>R</sub> SM (1)
YC476E	500	500	600
YC476M	600	600	720
YC476N	800	800	960
YC476P	1000	1000	1150
YC476PB	1200	1200	1300
YC476PD	1400	1400	1500

V<sub>RRM</sub> = Repetitive peak reverse voltage  
 V<sub>DRM</sub> = Repetitive peak off state voltage  
 V<sub>RSM</sub> = Non repetitive peak reverse voltage (2)

Repetitive peak reverse leakage and off state leakage	I <sub>RRM</sub> / I <sub>DRM</sub>	20mA 35 mA (3)
Critical rate of voltage rise	dV/dt (4)	400 V/μsec

**Conducting - on state**

Parameter	Symbol	Min.	Max.	Typ.	Units	Conditions
Average value of on-state current	I <sub>T(AV)</sub>		200		A	Sinewave, 180° conduction, T <sub>c</sub> = 65°C
RMS value of on-state current	I <sub>TRMS</sub>		600		A	Nominal value
Peak one cycle surge (non repetitive) current	I <sub>TSM</sub>		6000 5500		A A	8.3 msec (60Hz), sinusoidal wave-shape, 180° conduction, T <sub>j</sub> = 125 °C 10.0 msec (50Hz), sinusoidal wave-shape, 180° conduction, T <sub>j</sub> = 125 °C
I square t	I <sup>2</sup> t		150000		A <sup>2</sup> s	8.3 msec
Latching current	I <sub>L</sub>		800		mA	V <sub>D</sub> = 24 V; R <sub>L</sub> = 12 ohms
Holding current	I <sub>H</sub>		400		mA	V <sub>D</sub> = 24 V; I = 2.5 A
Peak on-state voltage	V <sub>TM</sub>		2.50		V	I <sub>TM</sub> = 1200 A;
Critical rate of rise of on-state current (5, 6)	di/dt		800		A/μs	Switching from V <sub>DRM</sub> ≤ 1000 V, non-repetitive
Critical rate of rise of on-state current (6)	di/dt		400		A/μs	Switching from V <sub>DRM</sub> ≤ 1000 V

Notes:

All ratings are specified for T<sub>j</sub> = 25 °C unless otherwise stated.

- (1) All voltage ratings are specified for an applied 50Hz/60Hz sinusoidal waveform over the temperature range -40 to +125 °C.
- (2) 10 msec. max. pulse width
- (3) Maximum value for T<sub>j</sub> = 125 °C.
- (4) Minimum value for linear and exponential waveshape to 80% rated V<sub>DRM</sub>. Gate open. T<sub>j</sub> = 125 °C.
- (5) Non-repetitive value.
- (6) The value of di/dt is established in accordance with EIA/NIMA Standard RS-397, Section 5-2-2-6. The value defined would be in addition to that obtained from a snubber circuit, comprising a 0.2 μF capacitor and 20 ohms resistance in parallel with the thyristor under test.

## ELECTRICAL CHARACTERISTICS AND RATINGS (cont'd)

## YC476 - Power Thyristor

### Gating

Parameter	Symbol	Min.	Max.	Typ.	Units	Conditions
Peak gate power dissipation	$P_{GM}$		200		W	$t_p = 40 \mu s$
Average gate power dissipation	$P_{G(AV)}$		5		W	
Peak gate current	$I_{GM}$		10		A	
Gate current required to trigger all units	$I_{GT}$		300 200 125		mA mA mA	$V_D = 6 V; R_L = 3 \text{ ohms}; T_j = -40^\circ C$ $V_D = 6 V; R_L = 3 \text{ ohms}; T_j = +25^\circ C$ $V_D = 6 V; R_L = 3 \text{ ohms}; T_j = +125^\circ C$
Gate voltage required to trigger all units	$V_{GT}$	0.30	5 3		V V V	$V_D = 6 V; R_L = 3 \text{ ohms}; T_j = -40^\circ C$ $V_D = 6 V; R_L = 3 \text{ ohms}; T_j = 0-125^\circ C$ $V_D = \text{Rated } V_{DRM}; R_L = 1000 \text{ ohms}; T_j = +125^\circ C$
Peak negative voltage	$V_{GRM}$		5		V	

### Dynamic

Parameter	Symbol	Min.	Max.	Typ.	Units	Conditions
Delay time	$t_d$		1.5	0.7	$\mu s$	$I_{TM} = 50 A; V_D = 67\% V_{DRM}$ Gate pulse: $V_G = 30 V; R_G = 10 \text{ ohms}; t_r = 0.1 \mu s; t_p = 20 \mu s$
Turn-off time (with $V_R = -5 V$ )	$t_q$		20		$\mu s$	$I_{TM} > 500 A; di/dt = 25 A/\mu s;$ $V_R \geq -5 V; \text{Re-applied } dV/dt = 200V/\mu s \text{ linear to } 67\% V_{DRM};$ $T_j = 125^\circ C; \text{Duty cycle } \geq 0.01\%$
Reverse recovery charge	$I_{rr}$				$\mu C$	$I_{TM} > 1000 A; di/dt = 25 A/\mu s;$ $V_R \geq -50 V; T_j = 125^\circ C$

## THERMAL AND MECHANICAL CHARACTERISTICS AND RATINGS

Parameter	Symbol	Min.	Max.	Typ.	Units	Conditions
Operating temperature	$T_j$	-40	+125		$^\circ C$	
Storage temperature	$T_{stg}$	-40	+150		$^\circ C$	
Thermal resistance - junction to case	$R_{\theta(j-c)}$		0.055 0.110		$^\circ C/W$	Double sided cooled Single sided cooled
Thermal resistance - case to sink	$R_{\theta(c-s)}$		0.030 0.060		$^\circ C/W$	Double sided cooled * Single sided cooled
Mounting force	P	800 3.6	2500 11.2		lb. kN	
Weight	W			2.5 70	oz g.	

\* Mounting surfaces smooth, flat and greased

CASE OUTLINE AND DIMENSIONS

