



RAE

YC612 - Power Thyristor

1200 - 2200 V_{DRM}; 1180A rms

HIGH POWER THYRISTOR FOR INVERTER APPLICATIONS

Features:

- . All Diffused Structure
- . Interdigitated Amplifying Gate Configuration
- . Blocking capability up to 2200 volts
- . Guaranteed Maximum Turn-Off Time
- . High dV/dt Capability
- . Pressure Assembled Device

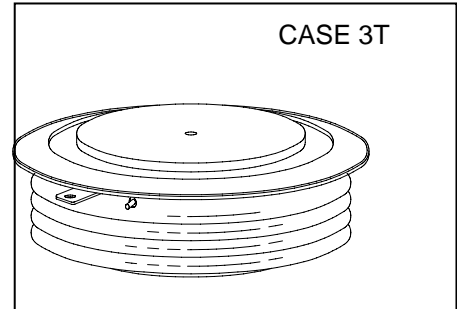

ELECTRICAL CHARACTERISTICS AND RATINGS

Blocking - Off State

Device Type	V _{RRM} (1)	V _{DRM} (1)	V _{RSM} (1)
YC612PB	1200	1200	1325
YC612PD	1400	1400	1525
YC612PM	1600	1600	1750
YC612PN	1800	1800	2000
YC612L	2000	2000	2200
YC612LB	2200	2200	2400

V_{RRM} = Repetitive peak reverse voltage
 V_{DRM} = Repetitive peak off state voltage
 V_{RSM} = Non repetitive peak reverse voltage (2)

Repetitive peak reverse leakage and off state leakage	I _{RRM} / I _{DRM}	15 mA 35 mA (3)
Critical rate of voltage rise	dV/dt (4)	500 V/μsec

Conducting - on state

Parameter	Symbol	Min.	Max.	Typ.	Units	Conditions
Average value of on-state current	I _{T(AV)}		725		A	Sinewave, 180° conduction, T _c =65°C
RMS value of on-state current	I _{TRMS}		1150		A	Nominal value
Peak one cycle surge (non repetitive) current	I _{TSM}		9000		A	8.3 msec (60Hz), sinusoidal wave-shape, 180° conduction, T _j = 125 °C
			8500		A	10.0 msec (50Hz), sinusoidal wave-shape, 180° conduction, T _j = 125 °C
I square t	I ² t		155000		A ² s	8.3 msec
Latching current	I _L		400		mA	V _D = 24 V; R _L = 12 ohms
Holding current	I _H		400		mA	V _D = 24 V; I = 2.5 A
Peak on-state voltage	V _{TM}		2.21		V	I _{TM} =2000 A; T _j = 125 °C
Critical rate of rise of on-state current (5, 6)	di/dt		800		A/μs	Switching from V _{DRM} ≤ 1000 V, non-repetitive
Critical rate of rise of on-state current (6)	di/dt		400		A/μs	Switching from V _{DRM} ≤ 1000 V

Notes:

All ratings are specified for T_j=25 °C unless otherwise stated.

- (1) All voltage ratings are specified for an applied 50Hz/60zHz sinusoidal waveform over the temperature range -40 to +125 °C.
- (2) 10 msec. max. pulse width
- (3) Maximum value for T_j = 125 °C.
- (4) Minimum value for linear and exponential waveshape to 80% rated V_{DRM}. Gate open. T_j = 125 °C.
- (5) Non-repetitive value.
- (6) The value of di/dt is established in accordance with EIA/NIMA Standard RS-397, Section 5-2-2-6. The value defined would be in addition to that obtained from a snubber circuit, comprising a 0.2 μF capacitor and 20 ohms resistance in parallel with the thristor under test.

ELECTRICAL CHARACTERISTICS AND RATINGS (cont'd) YC612 - Power Thyristor

Gating

Parameter	Symbol	Min.	Max.	Typ.	Units	Conditions
Peak gate power dissipation	P_{GM}		200		W	$t_p = 40 \mu s$
Average gate power dissipation	$P_{G(AV)}$		5		W	
Peak gate current	I_{GM}		10		A	
Gate current required to trigger all units	I_{GT}		300 200 125		mA mA mA	$V_D = 6 V; R_L = 3 \text{ ohms}; T_j = -40^\circ C$ $V_D = 6 V; R_L = 3 \text{ ohms}; T_j = +25^\circ C$ $V_D = 6 V; R_L = 3 \text{ ohms}; T_j = +125^\circ C$
Gate voltage required to trigger all units	V_{GT}	0.30	5 3		V V V	$V_D = 6 V; R_L = 3 \text{ ohms}; T_j = -40^\circ C$ $V_D = 6 V; R_L = 3 \text{ ohms}; T_j = 0-125^\circ C$ $V_D = \text{Rated } V_{DRM}; R_L = 1000 \text{ ohms}; T_j = +125^\circ C$
Peak negative voltage	V_{GRM}		5		V	

Dynamic

Parameter	Symbol	Min.	Max.	Typ.	Units	Conditions
Delay time	t_d		1.5	0.8	μs	$I_{TM} = 50 A; V_D = 67\% V_{DRM}$ Gate pulse: $V_G = 30 V; R_G = 10 \text{ ohms};$ $t_r = 0.1 \mu s; t_p = 20 \mu s$
Turn-off time (with $V_R = -5 V$)	t_q		55	50	μs	$I_{TM} > 500 A; di/dt = 25 A/\mu s;$ $V_R \geq -5 V; \text{Re-applied } dV/dt = 200$ $V/\mu s \text{ linear to } 67\% V_{DRM};$ $T_j = 125^\circ C; \text{Duty cycle } \geq 0.01\%$
Reverse recovery charge	I_{rr}				μC	$I_{TM} > 1000 A; di/dt = 25 A/\mu s;$ $V_R \geq -50 V; T_j = 125^\circ C$

THERMAL AND MECHANICAL CHARACTERISTICS AND RATINGS

Parameter	Symbol	Min.	Max.	Typ.	Units	Conditions
Operating temperature	T_j	-40	+125		$^\circ C$	
Storage temperature	T_{stg}	-40	+140		$^\circ C$	
Thermal resistance - junction to case	$R_{\theta(j-c)}$		0.040 0.080		$^\circ C/W$	Double sided cooled Single sided cooled
Thermal resistance - case to sink	$R_{\theta(c-s)}$		0.015 0.030		$^\circ C/W$	Double sided cooled * Single sided cooled
Mounting force	P	3000 13.4	3500 15.7		lb. kN	
Weight	W			9 255	oz g.	

* Mounting surfaces smooth, flat and greased

CASE OUTLINE AND DIMENSIONS

